

立面圖A  
Elevation Plan A

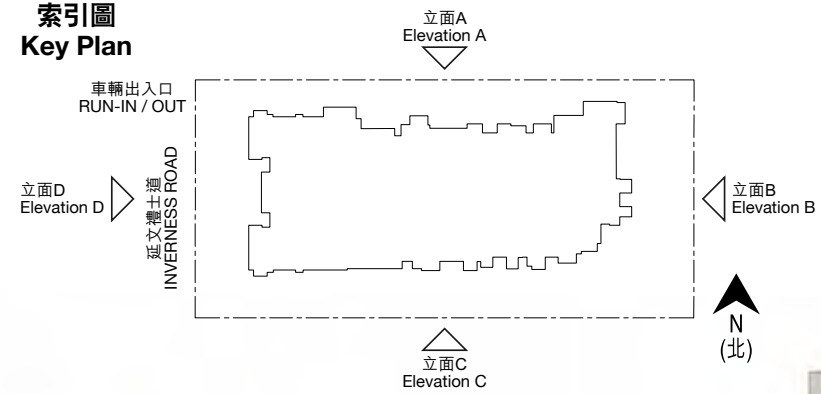

索引圖  
Key Plan



立面圖B  
Elevation Plan B



發展項目的認可人士證明本立面圖所顯示的立面：

1. 以2019年7月30日的情況為準的發展項目的經批准的建築圖則為基礎擬備；及
2. 大致上與發展項目的外觀一致。

The Authorized Person for the Development certified that the elevations shown on this elevation plan:

1. are prepared on the basis of the approved building plans for the Development as of 30 Jul 2019; and
2. are in general accordance with the outward appearance of the Development.





發展項目的認可人士證明本立面圖所顯示的立面：

1. 以2019年7月30日的情況為準的發展項目的經批准的建築圖則為基礎擬備；及
2. 大致上與發展項目的外觀一致。

The Authorized Person for the Development certified that the elevations shown on this elevation plan:

1. are prepared on the basis of the approved building plans for the Development as of 30 Jul 2019; and
2. are in general accordance with the outward appearance of the Development.